

RUDDER - REMOVAL/INSTALLATION

1. General

- A. The rudder consists of a spar, ribs, leading and trailing edge skins, hinge brackets, and a torque tube. These assemblies are riveted together using conventional universal head rivets. A balance weight is attached to upper forward leading edge.

2. Rudder Removal/Installation

- A. Remove Rudder (Refer to Figure 401).

- (1) Remove screws attaching stinger to tailcone and remove stinger.
- (2) If installed, disconnect tail navigation light wire at quick-disconnect. Refer to Chapter 33, Incandescent Navigation Lights - Maintenance Practices Stinger Navigation Light Removal/Installation.
- (3) Remove cotter pins and clevis bolt nuts from rudder cable attach bolts at torque tube (12).
- (4) Remove cotter pins from rudder hinge bolt nuts (7), (14), and (15), and remove nuts.
- (5) With rudder supported, remove hinge bolts (6), (11), and (17).
- (6) Remove rudder (1).

- B. Install Rudder (Refer to Figure 401).

- (1) Position rudder so that hinge bolt holes in rudder align with hinge bearings (5), (9), and (16).

NOTE: Instructions for fabricating an elevator attach bolt installation tool are shown on Figure 402. The tool may be used to securely hold rudder attach bolt when inserting it into rudder hinge. To use tool, insert head of bolt between clip and handle of tool.

- (2) Install hinge bolts (6), (11), and (17) and nuts (7), (14), and (15), respectively. Safety with cotter pins.
- (3) Install clevis bolts attaching rudder cables to torque tube (12). Safety nuts with cotter pins (8).
- (4) Connect tail navigation light wire at quick-disconnect.
- (5) Install stinger to tailcone with attach screws.
- (6) Check rudder travel in accordance with Chapter 27. Rerig as required.

Figure 401 : Sheet 1 : Rudder Installation

A22220

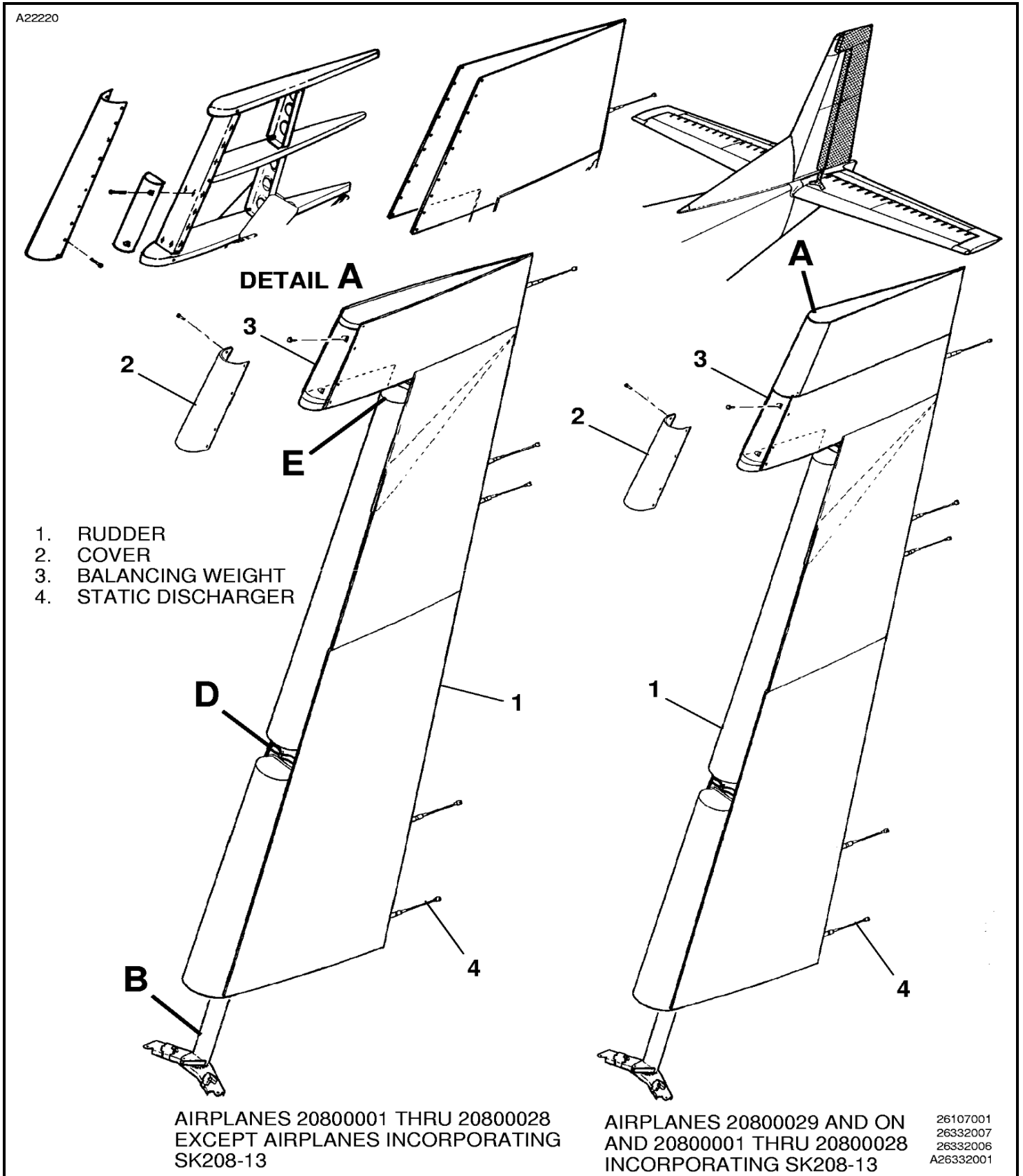
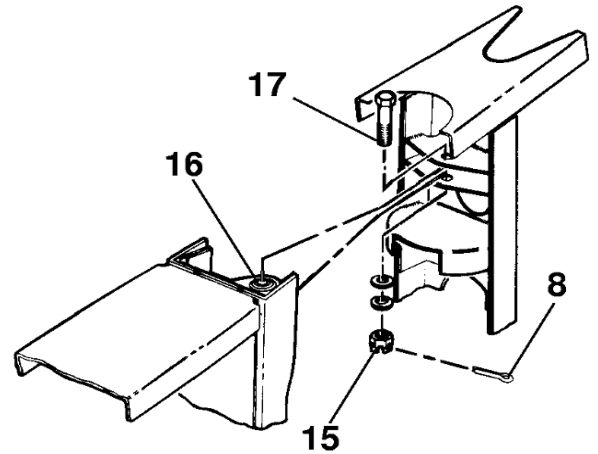

Figure 401 : Sheet 2 : Rudder Installation

A22221

- 5. CENTER HINGE BEARING
- 6. CENTER HINGE BOLT
- 7. CENTER HINGE BOLT NUT
- 8. COTTER PIN
- 9. LOWER HINGE BEARING
- 10. GROUND STRAP
- 11. LOWER HINGE BOLT
- 12. TORQUE TUBE
- 13. STOP BOLT
- 14. LOWER HINGE BOLT NUT
- 15. UPPER HINGE BOLT NUT
- 16. UPPER HINGE BEARING
- 17. UPPER HINGE BOLT



DETAIL E

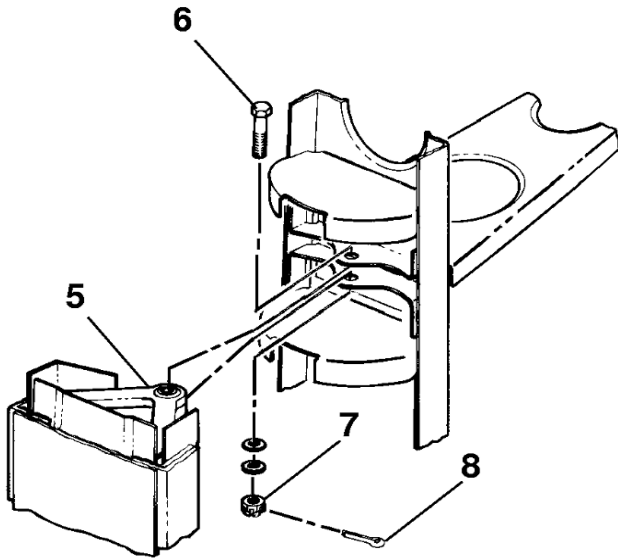

DETAIL D

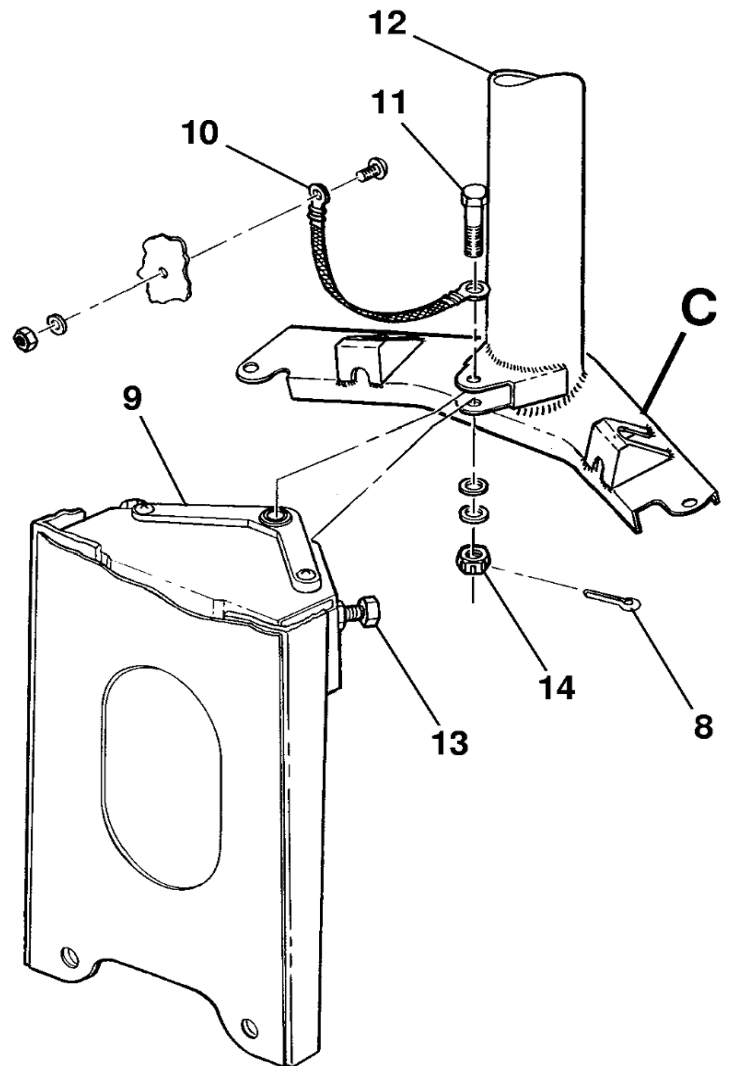

DETAIL B

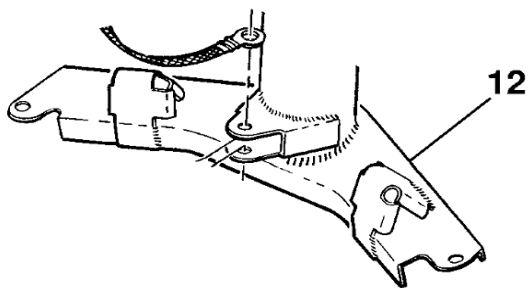

DETAIL C

AIRPLANES 20800001 THRU 20800095

B26331005A
 C26331005
 D26331007
 E26331006

Figure 402 : Sheet 1 : Rudder Bolt Installation Tool Fabrication

